

# CLIMA DOOR

SUPERIOR QUALITY – REALISTIC PRICE



**IMPORTANT** PLEASE READ AND UNDERSTAND THESE INSTRUCTIONS PRIOR TO COMMENCING INSTALLATION.

All doorsets supplied unfinished should be fully decorated prior to installation. This product is designed to comply with Part L & Part F of the building regulations.

Part M primary access compliance is only achieved if all doors leaves are opened and is dependant on the installation detail used. If in doubt consult your building designer.

All loads are taken on the head track (to ensure smooth, light operation and long life) thereby avoiding troublesome bottom track loading prone to dirt and restriction.

Prior to installing this doorset, inspect for damage and do not proceed to fit if any noticeable damage or defect is evident. This doorset should be stored in a dry flat location before installation.

## CAUTION



**SAFETY:** This product needs to be installed by a competent tradesperson with assistance. Two people are required to carry out the installation, as some components are heavy. The outer frame requires fixing to the supporting structure above the opening. The Lintel **MUST** be capable of carrying the load of the doorset in all conditions. If in doubt check with a structural engineer. Individual Door leaves can weigh up to 50kg

# SELECT.

54mm **WHITE PRIMED** FOLDING DOORS

### INTRODUCTION

To enable the arrangement of doors of the Sliding Folding Patio Doorset to operate either from the left or right certain operations that determine the handing of a door leaf will need to be undertaken on site.













The stiles of the door leaves will need to be pilot drilled to suit the arrangement of the hinges and holes to receive the lock cylinder and the bottom fixing screw of the handle set will need to be added to the mortise in the stile of the locking door leaf.

Information showing the position of the hinges and the preparation to the lock mortise are given in these instructions

Index:

- 1 - Frame Fixing Pack
- 2 - Structural opening
- 3 - Preparing the sill for assembly
- 4 - Frame assembly
- 5 - Fixing the frame into the structural opening
- 6 - Preparing the doors to receive the hinges
- 7 - Fitting the multipoint lock
- 8 - Preparing for multipoint lock keeps.
- 9 - Fitting the carrier and pivot hinges
- 10 - Hanging the doors
- 11 - Fitting the keeps and blanking plates
- 12 - Fitting the handles and lock cylinder
- 13 - Final adjustment of the doors
- 14 - Fitting the ventilator
- 15 - Finishing and maintenance
- 16 - Guarantees

### 01 FRAME FIXING PACK

Amount	Description	Image
54	3.5x37 CSK Pozidrive Twinhead Woodscrew	
14	7mmBrown Masonry Plugs	
18	5x80 self drilling screw CSK Pozidrive	
10	8x100 Frame Fixing Bolts	
8	5x90 CSK Pozidrive Woodscrew	
6	3.5x25 PAN Pozidrive Woodscrew	
10	Brown M6 push-in cover	
10	WhiteM6 push-in cover	
14	147x17 Tie Plate	
20	100x24 Wedge Packer (1 to 4mm)	
46	100x24 Flat Packer (3mm)	
64	100x24 Flat Packer (1mm)	

The number of components in the frame fixing pack suit the installation of a 4.8m wide doorset. For other widths there will be excess fittings.

### 02 STRUCTURAL OPENING

To ensure correct operation of the Sliding Folding Patio Doorset it is necessary for the top track to be fixed to a suitable structure that is capable of supporting the loads imposed by the doors, glazing and hardware. The systems supplied apply a uniformly distributed load of 50kg/leaf.

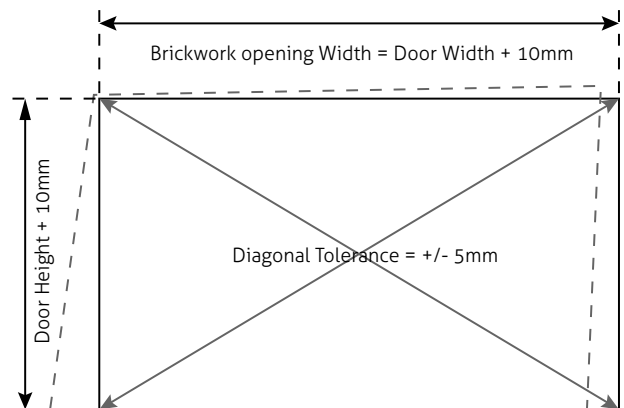

## D Fitting and Fixing Instructions

### Sliding Folding Patio Doorset

Module Size	Frame Width*	Frame Height*
1800mm	1795mm	2095mm
2100mm	2095mm	2095mm
2400mm	2395mm	2095mm
2700mm	2695mm	2095mm
3000mm	2995mm	2095mm
3600mm	3595mm	2095mm
4200mm	4195mm	2095mm
4800mm	4795mm	2095mm

It is recommended that the opening into which the Sliding Folding Patio Doorset is to be installed is 10mm larger in both height and width than the overall doorset sizes that are given in the table.

**The horizontal and vertical surfaces of the structural opening should be checked with a spirit level and the diagonals of the opening should be within 5mm of each other.**

## 03 PREPARING THE SILL FOR ASSEMBLY

Prior to assembling the frame prepare each component for installation by drilling as described below:

### SILL ASSEMBLY

If the aluminum section and timber part of the sill are not pre-assembled they should be fixed together as follows; apply a bead of silicon to the rebate in the top of the timber part (as shown) push the timber part into the aluminium part so that it is fully home. Fix this in place by drilling through the aluminium at each end of the sill & at 1000 centres approx and inserting 3.5mm x 25mm pan head screws to firmly fix the timber Back Sill to the aluminium along its length

### PILOT DRILLING FOR TIE PLATES

In preparation for the sill fixings pilot drill 2.5 x 25mm into the underside of the sill assembly, through the aluminium and into the timber, at the positions shown in the frame fixings diagram below, 100mm, 250mm and 400mm from each end then at not more than 400mm centres in between.

Ensure the tie plates are fixed through both the aluminium and timber profiles.

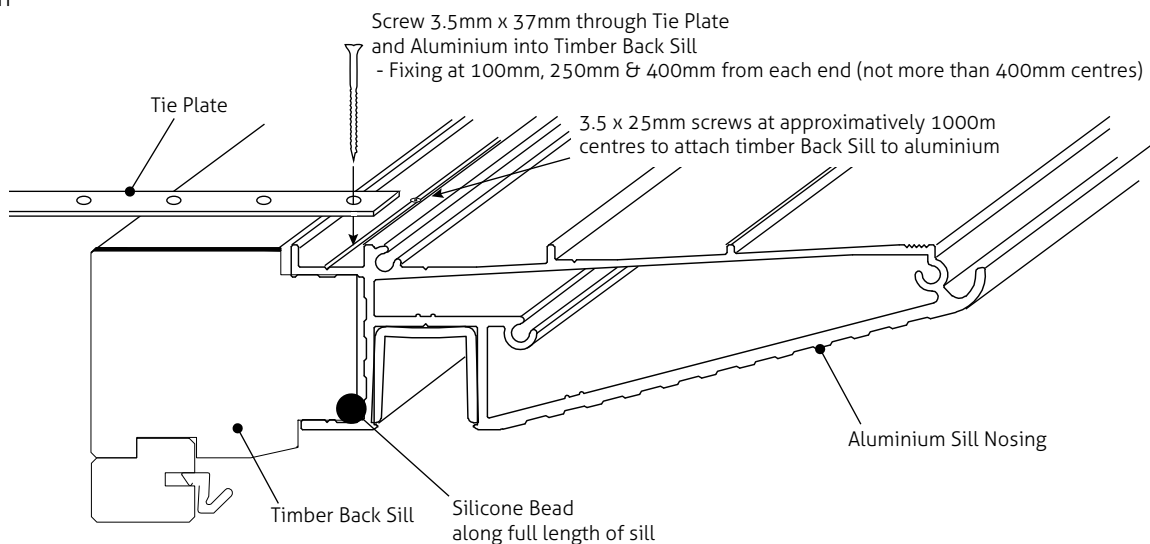

## D Fitting and Fixing Instructions

### Sliding Folding Patio Doorset

#### 04 FRAME ASSEMBLY

The four assemblies that together form the frame of the Sliding Folding Patio Doorset are fixed together using the 8 No. 5 x 90 woodscrews and the gaskets.

Apply silicone sealant to:

- each end of the head assembly
- either side of the tenon at the sill end of each jamb assembly
- each end of the stops of each jamb assembly All as shown in the drawing below

Screw fix the jamb assembly to the head assembly with 2no 5x90mm woodscrews in each end.

Locate the tenon at the sill end of the jamb assembly into the channel in the sill assembly and screw-fix with 2 No. 5 x 90 woodscrews at each end.

Check that the corners of the frame are square and that the diagonals of the frame measure to within 5mm of each other.

If they do not, loosen the screws at the joints, adjust the frame then retighten the joints.

After assembling the frame check your internal frame rebate sizes

Frame Width*	Internal Rebate Size*
1795mm	1731mm
2095mm	2031mm
2395mm	2331mm
2695mm	2631mm
2995mm	2931mm
3595mm	3531mm
4195mm	4131mm
4795mm	4731mm

\* +/- 1mm

#### 05 FIXING FRAME IN OPENING

The four assemblies that together form the frame of the Sliding Folding Patio Doorset are fixed together using the 8 No. 5 x 90 woodscrews and the gaskets.

##### INSTALLING THE HEAD TRACK

There are 2 options for installing the head track.

**Option 1:** You can install the head track in one full length, however, before fixing up into lintel you must ensure that all of the running gear and pivots are fed into the track in the right order. Please refer to section 6 - hinge positions to find out the correct order.

**Option 2:** You can cut off a 50mm section of the head track to create an access slot (see handy tip opposite). The remaining long length can then be installed fixing through the track and head into the lintel. The 50mm cut off section can then be used as an access slot to feed in the running gear and pivots later in the installation.

Once the running gear has been fed into the track in the correct order, the 50mm section can then be re-installed and fixed up to the lintel through the fixing holes using appropriate fixings.

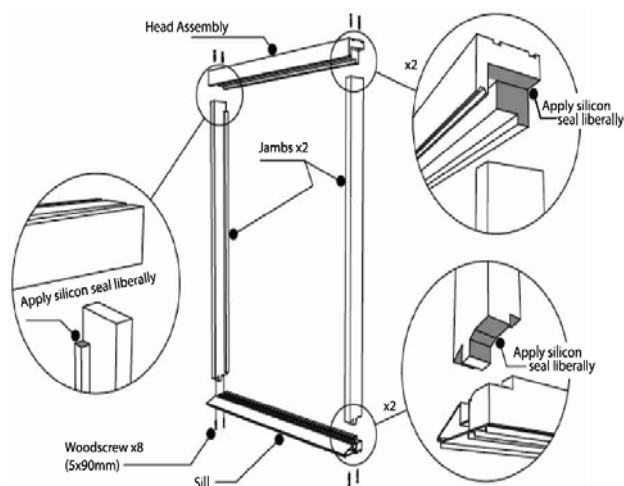

## D Fitting and Fixing Instructions

Sliding Folding Patio Doorset

### D HEADTRACK - HANDY TIP!



Cut track in 2 to produce access slot for pivots / carriers

#### INSTALLING TOP TRACK FOR 3R, 3R/1L, 5R & 5R/1L CONFIGURATIONS

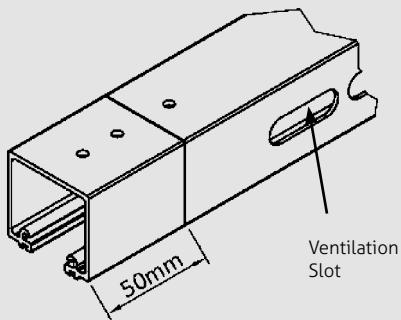

Ventilation Slots to the right. (Slots should align with the machining in the Head of the Frame)

#### INSTALLING TOP TRACK FOR 3L, 3L/R, 5L & 5L/1R CONFIGURATIONS

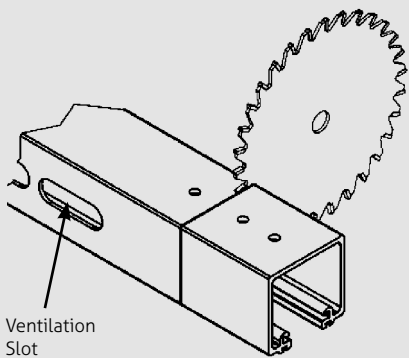

Ventilation Slots to the left. (Slots should align with the machining in the head of the Frame)

### D IMPORTANT



Please also refer to section 9 on the replacement & fixing of the short 50mm section which will take the load applied by the doors.

Offer the frame into the structural opening and adjust its position to ensure that the fixing holes in the head track are in the correct position to match the supporting structure (i.e. in the centre of the external flange of a lintel).

Fixing to reveal position one fixing 175mm from head and sill with additional fixings at not more than 450mm spacing in between.

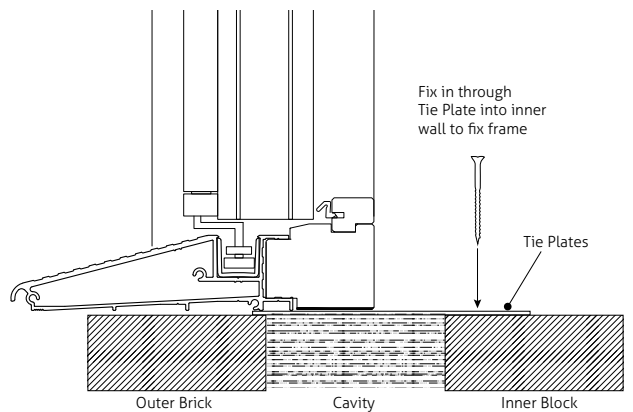
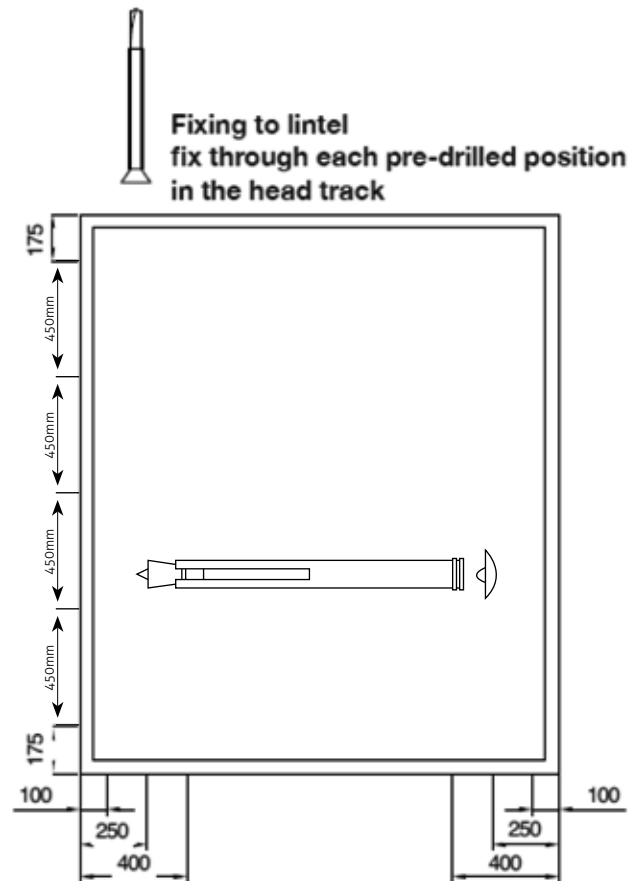

05 CONTINUED

## D Fitting and Fixing Instructions

### Sliding Folding Patio Doorset

#### 05 CONTINUED ▶

#### PRE-DRILLING

Once the position of the frame is correct, pre-drill the lintel through the head with a 4mm diameter hole using the prepared holes in the head track as a guide.

Remove the frame head, from this position, to allow pre-drilling of any masonry above the lintel.

The masonry will need to be drilled through the 4mm holes in the lintel to a depth of at least 40mm to receive the length of the fixing screw that passes through the lintel.

#### LOCATING THE FRAME

**When the position of the frame is correct place 5mm of packing above each jamb between the head and the top of the structural opening then place packers below the sill until the head packers are tight. (See diagram opposite)**

Using a spirit level, check that the head and sill are level, make adjustments as necessary, then pack at each of the sill fixing points ensuring that the sill remains level.

Use the spirit-level to check that the jambs are vertical. Position packers at each of the jamb fixing points ensuring that the diagonals of the frame remain within 2mm of each other.

#### FIXING JAMBS

While the frame is temporarily secured by the packers, and ensuring the frame is not knocked out of position, drill 8mm diameter holes 70mm into the structure either side of the frame through pre-prepared holes in the jambs.

Insert the frame fixing bolts through the jambs and into the structure and tighten ensuring the jambs are not distorted.

#### FIXING THE SILL

For each of the sill ties locate a suitable fixing point and drill for the 7mm masonry plug then fix the sill ties using the plugs and the remaining 3.5 x 37 woodscrews.

#### FIXING THE HEAD

In order to produce a camber in the head track as shown below the fixings to the head need to be fitted in stages reducing the gap between the head and the supporting structure at each stage.

Starting with the two outer fixings offer up the fixing screw and tighten until it is just pulling.

#### DO NOT FULLY TIGHTEN AT THIS STAGE.

**ENSURE THE 5MM PACKERS ARE IN PLACE BETWEEN THE HEAD AND THE LINTEL APPROX 50MM IN FROM EACH END OF THE HEAD AS SHOWN BELOW**

At a central fixing point lightly tighten a screw until the head is pulling close to the lintel.

Working from the jambs inwards lightly tighten screws varying the thickness of packing between the head and the lintel creating a slight upwards curve to the head varying from approximately 5mm at each jamb to zero in the middle.

Once the correct curve of the head has been achieved tighten the fixing screws.

#### DO NOT OVER-TIGHTEN

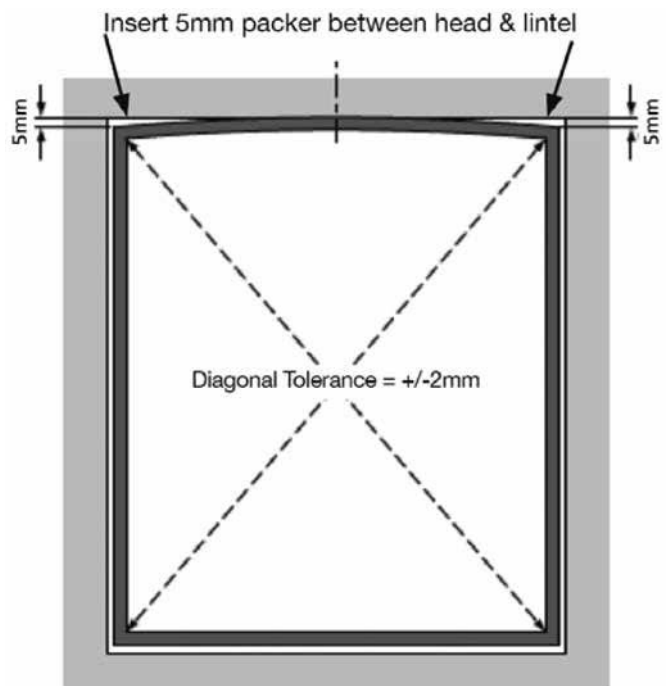

## D Fitting and Fixing Instructions

Sliding Folding Patio Doorset

### D IMPORTANT



Fixings must fix through the aluminium track, Frame Head & Lintel (The system is top hung so all the weight is supported from the top channel & head of the frame, hence the importance of fixing through the Lintel.)

#### PRESSED STEEL LINTEL

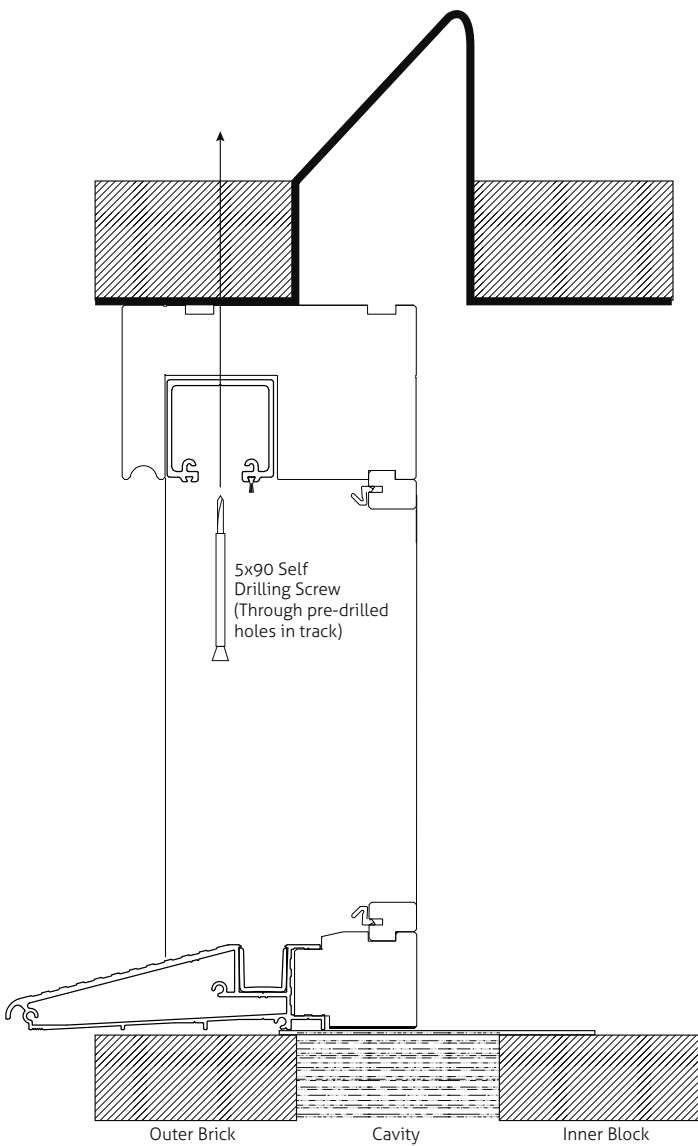

#### RSJ LINTEL

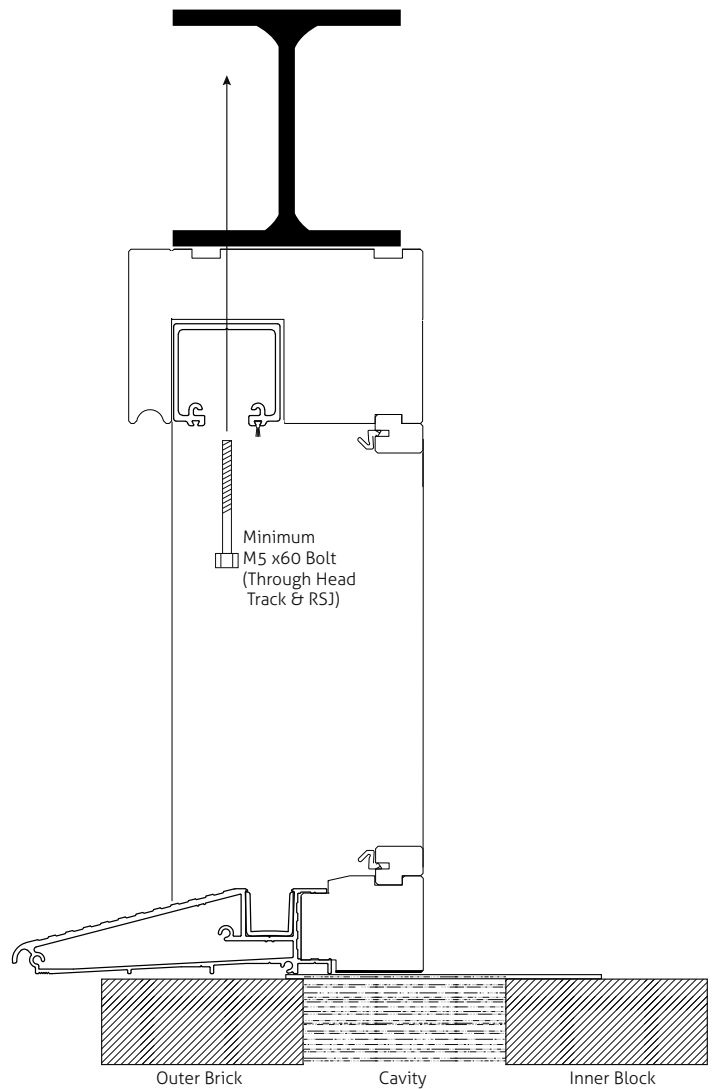

# D Fitting and Fixing Instructions

## Sliding Folding Patio Doorset

### 06 HINGE POSITIONS

The following drawings represent the various options available. Please select the drawings appropriate to the set up you have purchased.

Note carefully the positions of drop bolts, door codes (ie. A,B, C etc) & the view of the drilling detail compared to the plan view (as viewed from outside your property when installed)

The diagrams show door leaf edges with the relevant hinge positions. Where doors are hinged together, door edges are all correctly identified Door A, Door B etc,

Please refer to the plan view and check the door edges match their position on the plan. Under each detail is the hardware box reference you should be using.

	A	B	C	D	Nominal Size Width	Pattern Available
3 Door	1	1	1	0	1800mm/2100mm/2400mm/2700mm	3L or 3R
4 Door	1	1	1	1	3000mm	3L/1R/ or 3R/1L
5 Door	2	2	1	0	3600mm	5L or 5R
6 Door	2	2	1	1	4200mm/4800mm	5L/1R or 5R/1L or 3L/3R

#### Door & Hardware Arrangements.

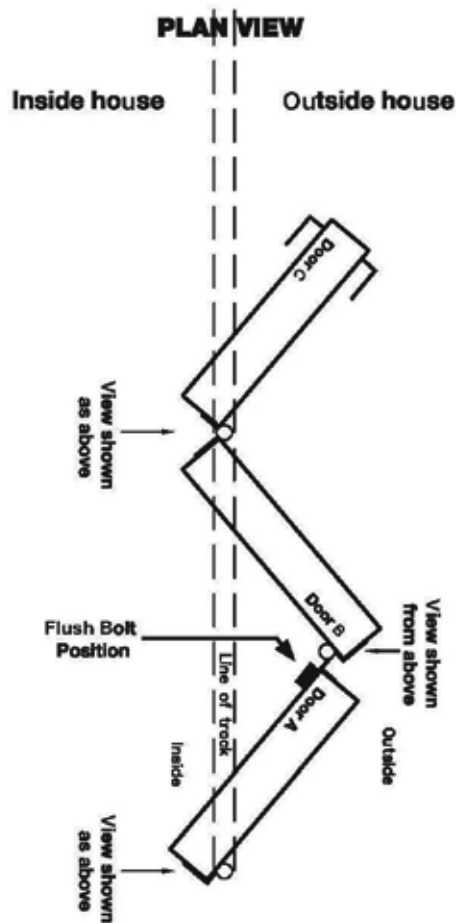

**3L**  
As viewed from outside

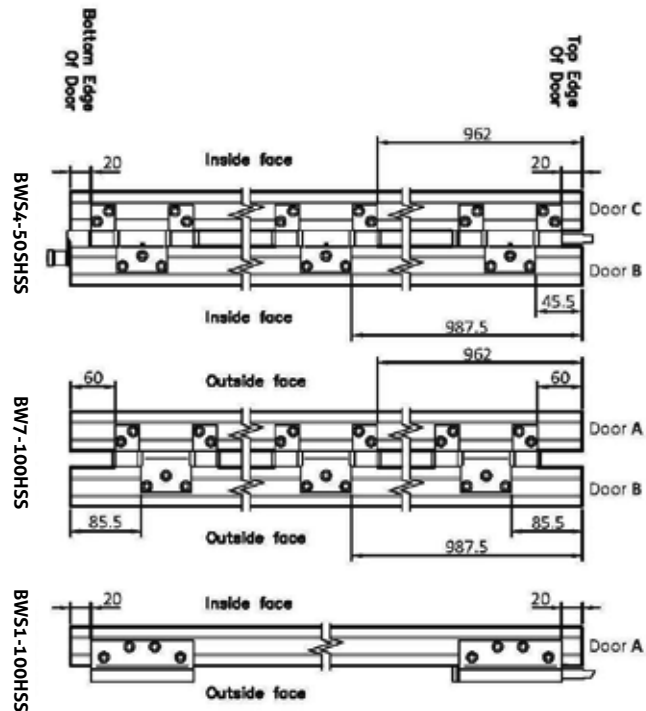

**NB.**  
The glazing beading should be on the inside of the door when fitted.



# D Fitting and Fixing Instructions

## Sliding Folding Patio Doorset

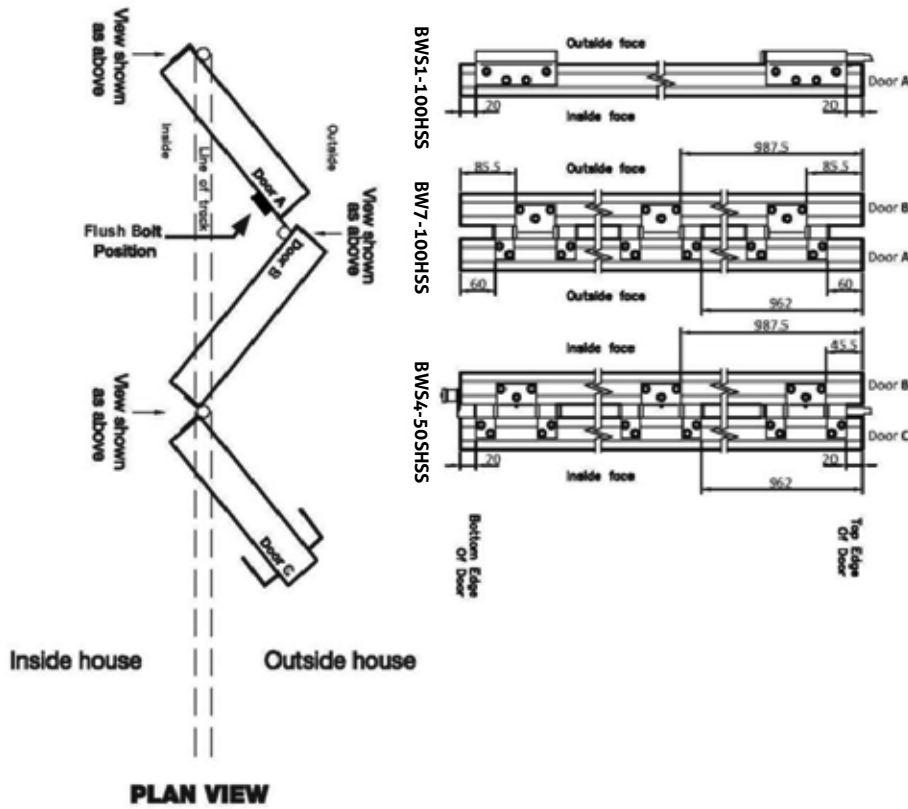

**3R**  
As viewed from outside

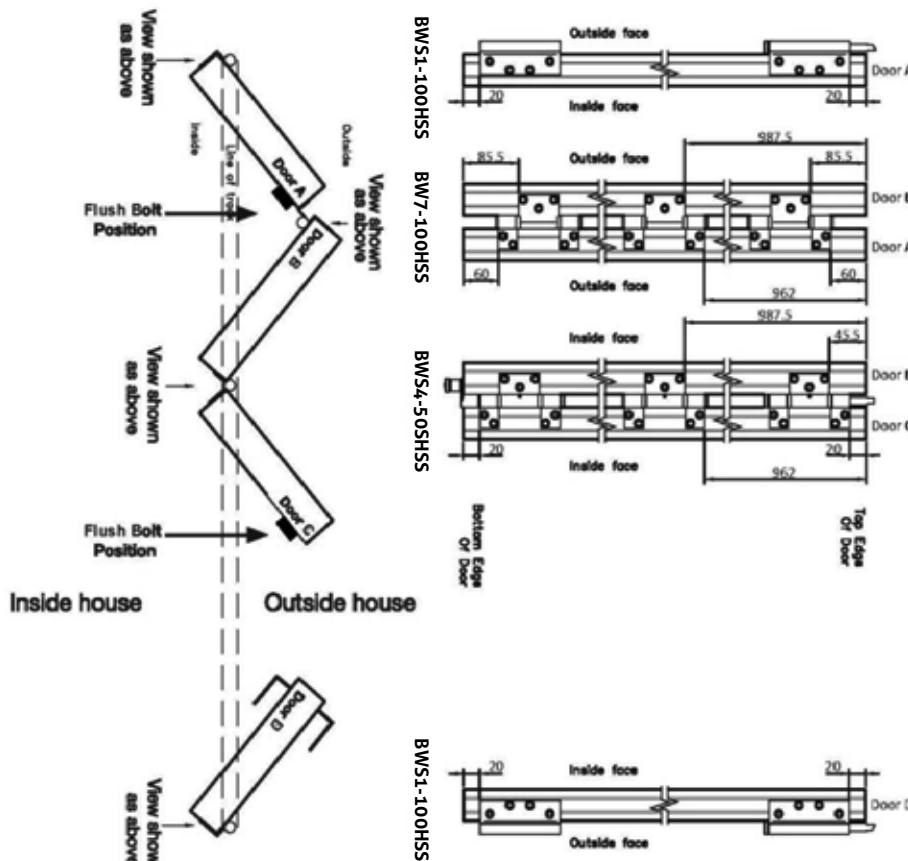

**1L3R**  
As viewed from outside

**NB.**  
The glazing beading should be on the inside of the door when fitted.

# D Fitting and Fixing Instructions

## Sliding Folding Patio Doorset

**3L1R**  
As viewed from outside

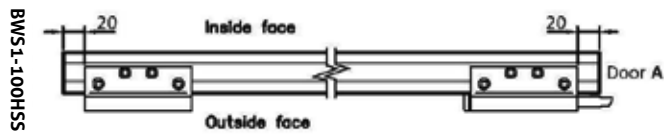
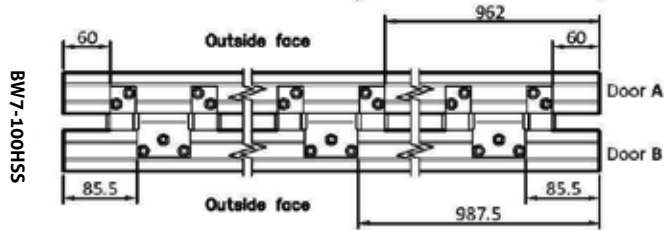
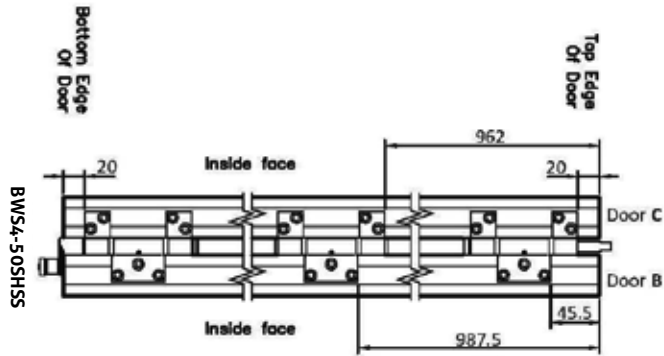
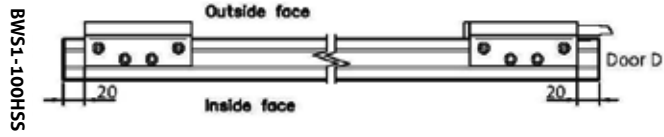
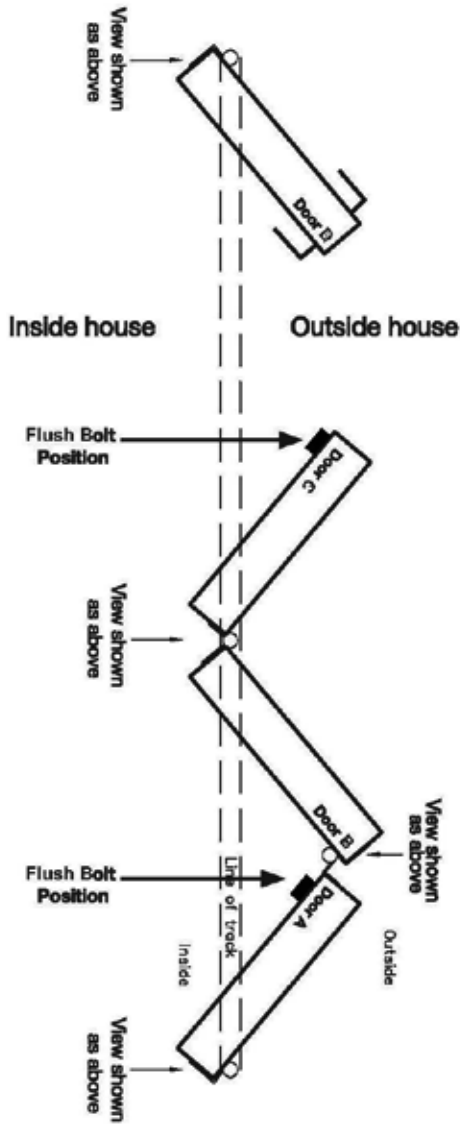

**NB.**  
The glazing beading should be on the inside of the door when fitted.

# D Fitting and Fixing Instructions

## Sliding Folding Patio Doorset

**5R**  
As viewed from outside

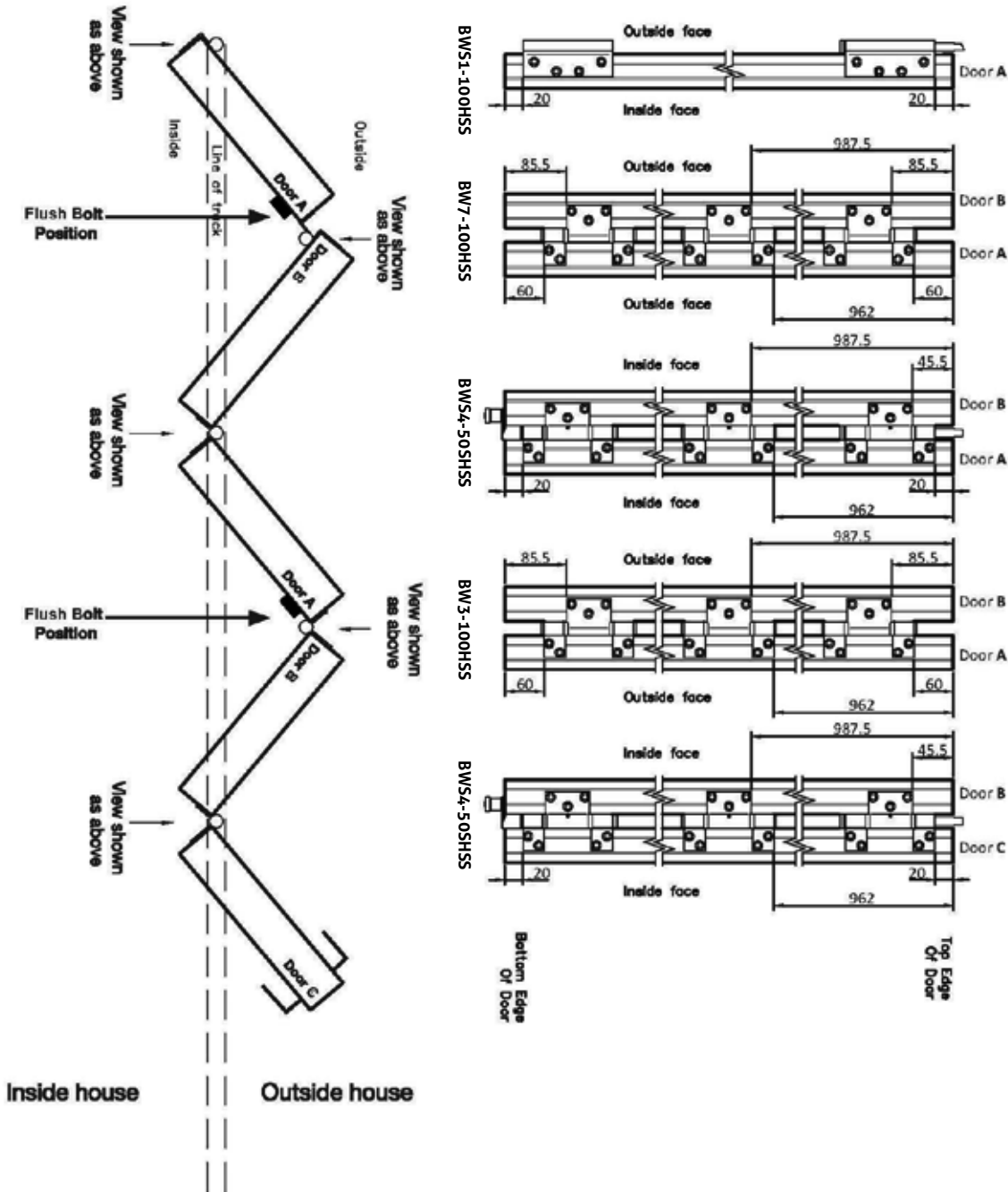

**NB.**  
The glazing beading should be on the inside of the door when fitted.

# D Fitting and Fixing Instructions

## Sliding Folding Patio Doorset

**5L**  
As viewed from outside

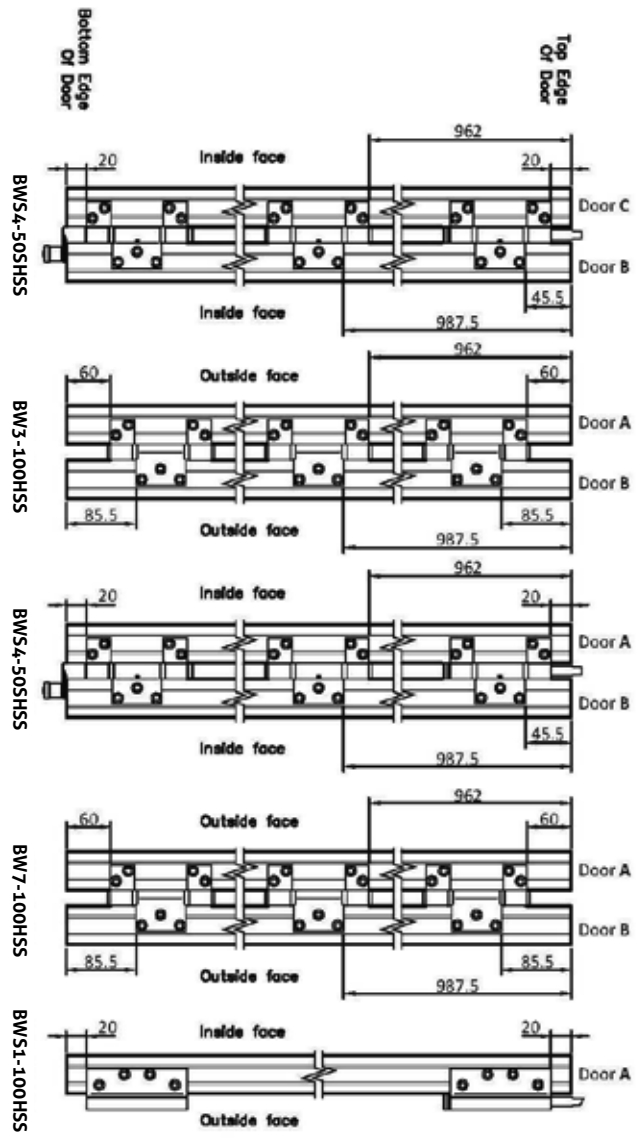
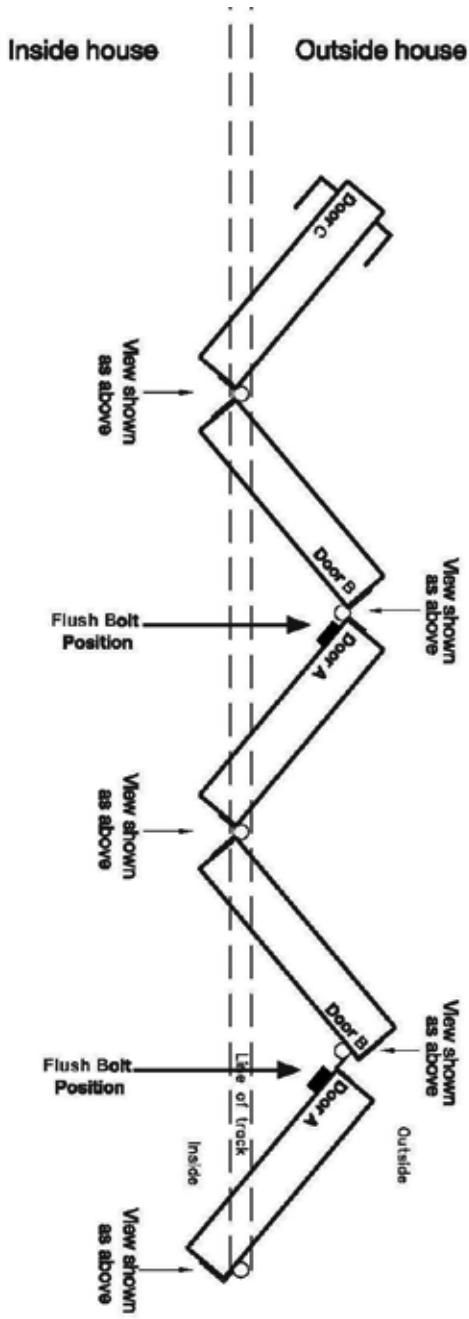

**NB.**  
The glazing beading should be on the inside of the door when fitted.

# D Fitting and Fixing Instructions

## Sliding Folding Patio Doorset

# 5L1R

As viewed from outside

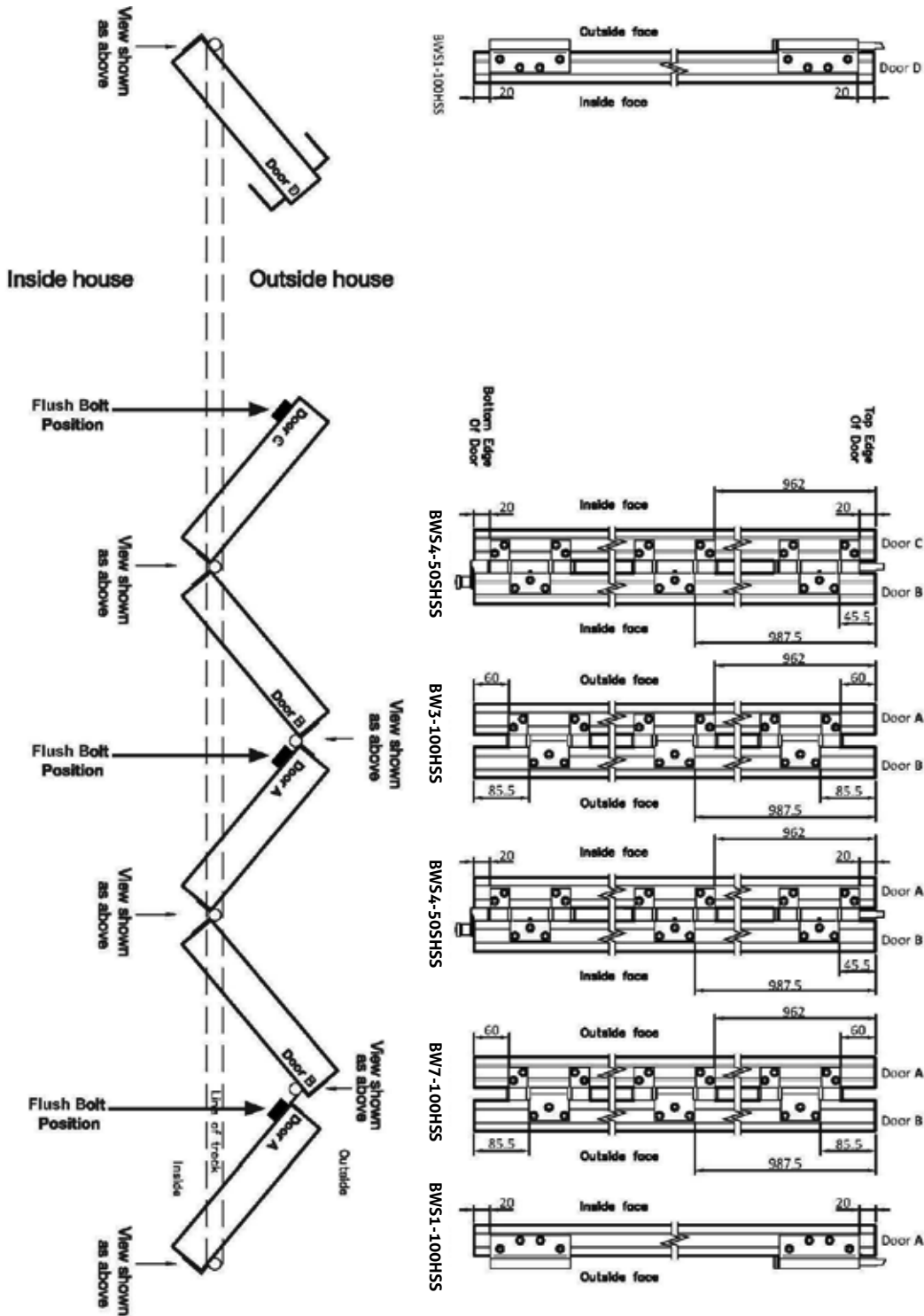

**NB.**  
The glazing beading should be on the inside of the door when fitted.

# D Fitting and Fixing Instructions

## Sliding Folding Patio Doorset

**1L5R**  
As viewed from outside

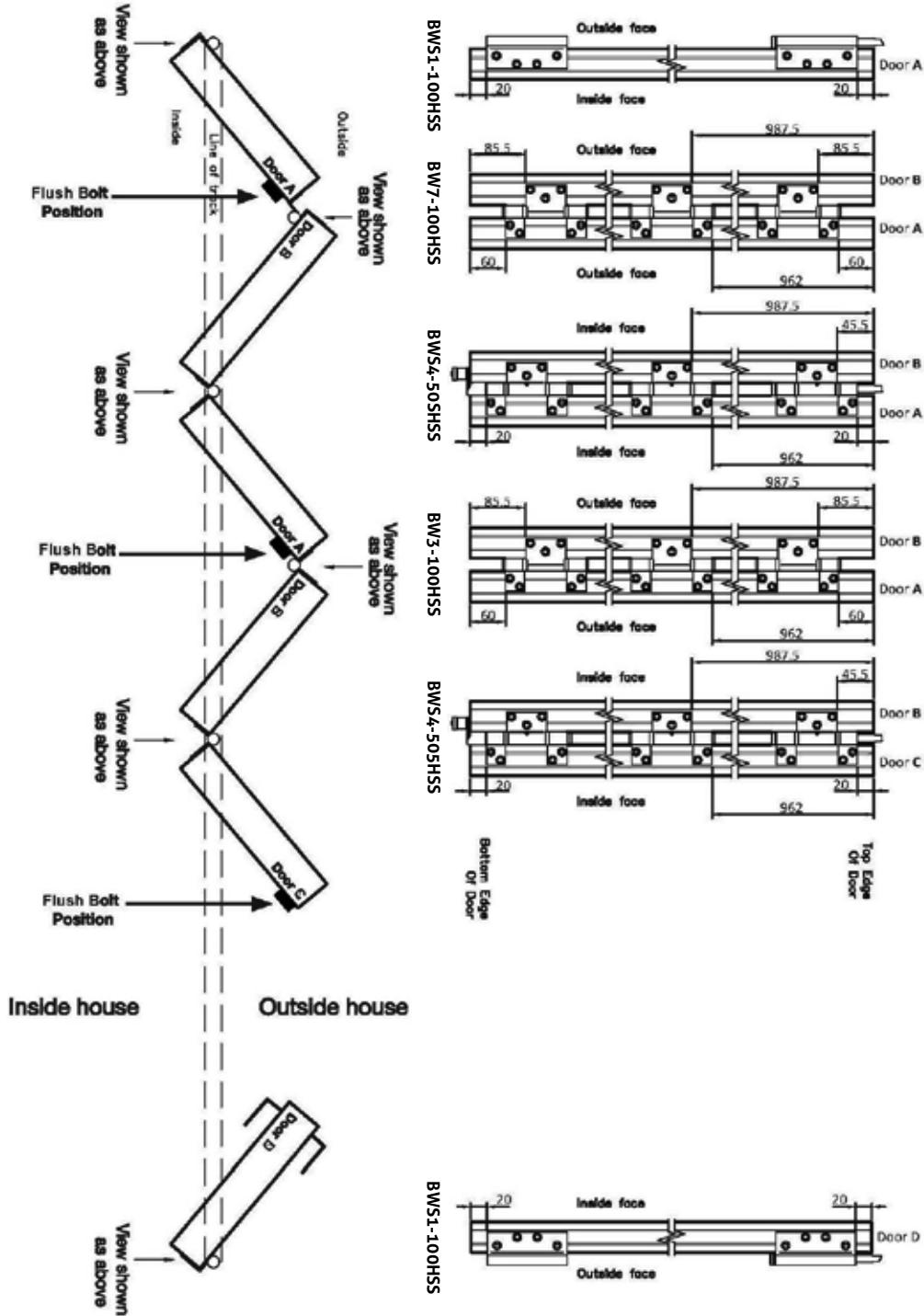

**NB.**  
The glazing beading should be on the inside of the door when fitted.



# Fitting and Fixing Instructions

## Sliding Folding Patio Doorset

# 3L3R

As viewed from outside

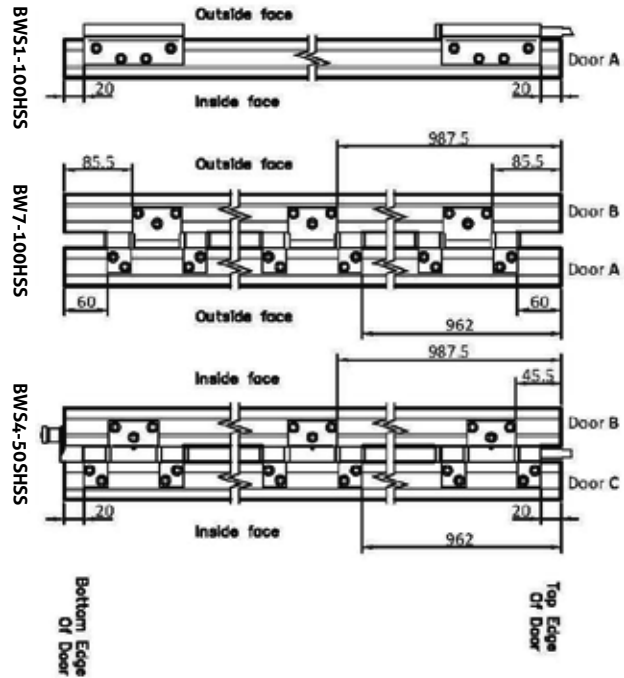
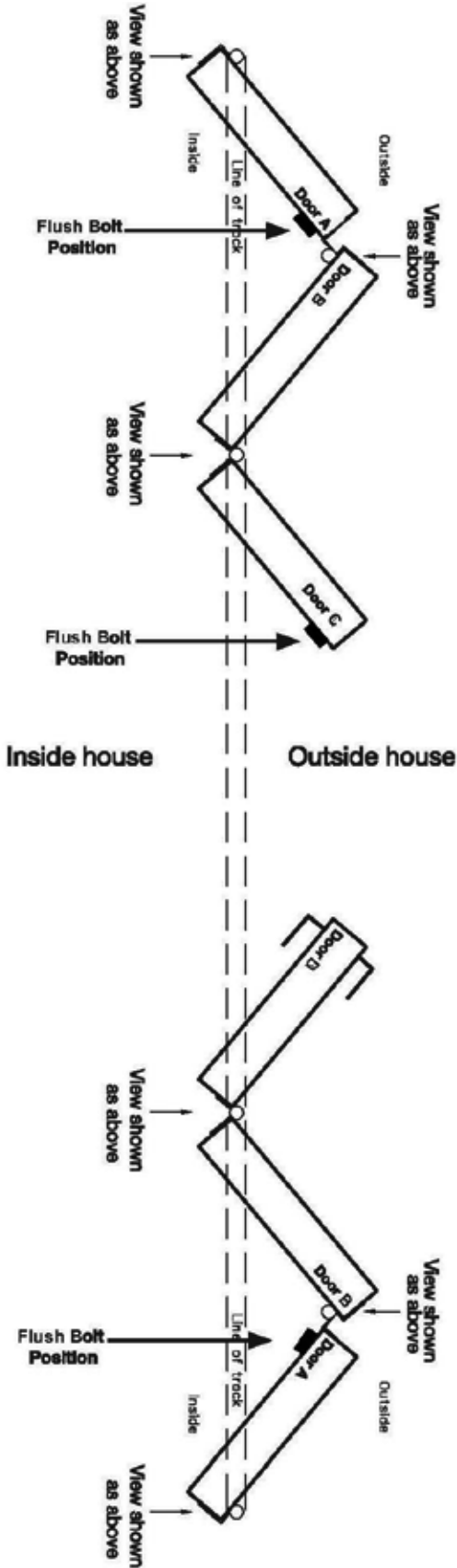

**NB.**  
The glazing beading should be on the inside of the door when fitted.

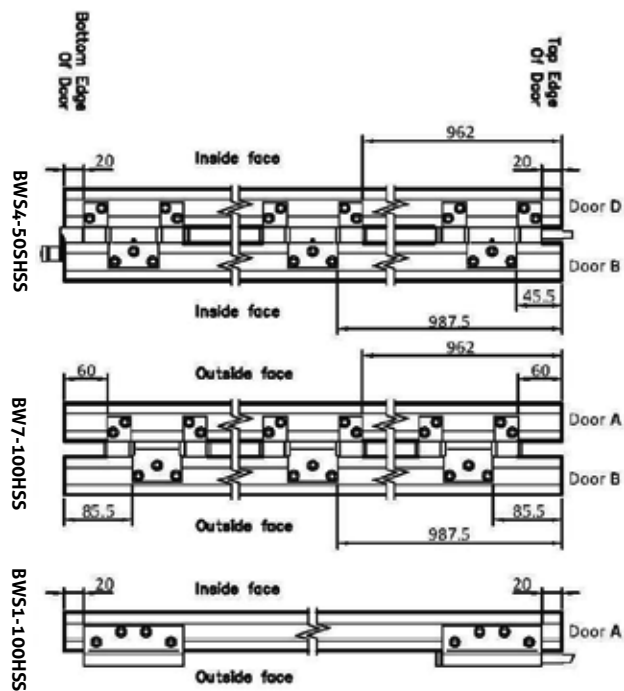

### 07 FITTING THE CARRIER AND PIVOT HINGES

In preparation for hanging the door leaves the carrier hinges need to be fitted into the top track in an appropriate order to suit the desired arrangement of doors.

All the carrier hinges are fed into the track through the access slot before the second shorter track is fixed into position. An access slot could be used at one or both ends of the top track.

Note: It is not important which end of the track the access point is located but the carrier hinges must be fed into the track in the correct order & the vent slots in the track must align with inside frame head machining.

Feed in the pivot hinges and carrier sets into the top track in accordance with this table:

Door Arrangement	Position of Carrier Hinges (Viewed from the outside)			
	Left Hand Side			Right Hand Side
3L	Pivot	Intermediate Carrier		
3R			Intermediate Carrier	Pivot
3L 1R	Pivot	Intermediate Carrier		Pivot
1L 3R	Pivot		Intermediate Carrier	Pivot
5L	Pivot	Intermediate Carrier	Intermediate Carrier	
5R		Intermediate Carrier	Intermediate Carrier	Pivot
5L 1R	Pivot	Intermediate Carrier	Intermediate Carrier	Pivot
1L 5R	Pivot	Intermediate Carrier	Intermediate Carrier	Pivot
3L 3R	Pivot	Intermediate Carrier	Intermediate Carrier	Pivot

### D IMPORTANT



Once all of the parts have been fed into the Head Track, if you have created an access slot by cutting a 50mm section off the Head Track as per the "Handy Tip" in section 5 you must fix this section back in with 2no fixings that fix through to the Lintel.



## D Fitting and Fixing Instructions

### Sliding Folding Patio Doorset

#### 07 CONTINUED ▶

**WHEN THE GLAZING IS BEADED THE BEADS SHOULD BE FACING TOWARDS THE INSIDE OF THE BUILDING.**

**WHERE A HINGE OBSTRUCTS THE WEATHERSEAL CUT THE WEATHERSEAL AROUND THE HINGE. THE HINGES MUST NOT HAVE WEATHERSEAL TRAPPED BENEATH THEM.**

Doors should be fitted to the pivot hinges first. Use pre-drilled pilot holes to fix the hinge to prevent splitting (screws are provided in the hinge pack).

**Adjust the top and bottom pivot hinges to ensure the door is vertical before attempting to hang the next door**

Once pivot door fitted start adding further panels to the assembly. You must follow the illustrations on the 'Door & Hardware Arrangement Sheet' for correct hardware to be used at the correct position on the doorset. Failing to do so will result in incorrect door assembly and may damage the door panels

Bring pivot panel to pivot set

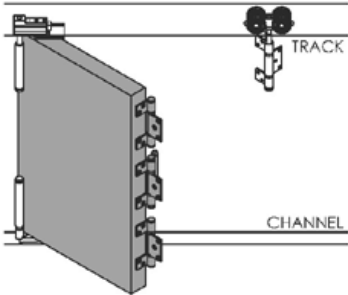

Bring 2nd panel to pivot panel

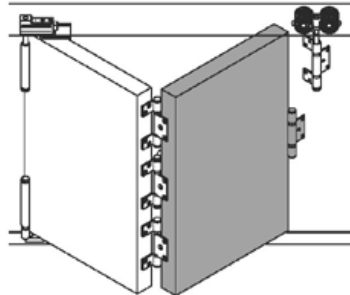

Fix int. hanger to int. panel

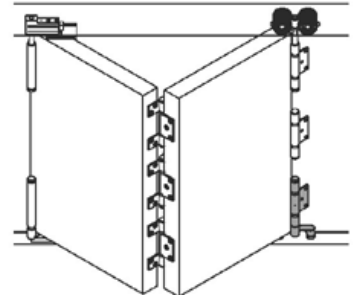

Attach int. guide to int. panel

Bring 3rd panel to the int. hanger

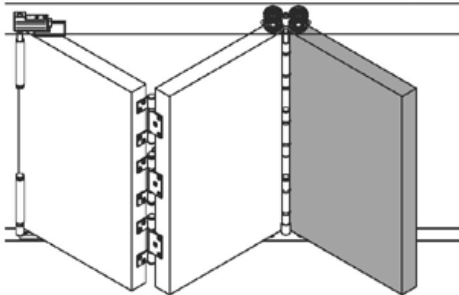

Repeat steps for any remaining doors

Close all panels before starting adjustment

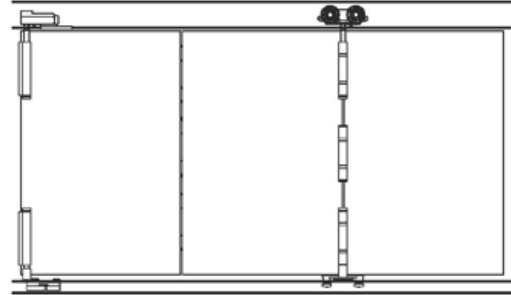

**08 HANGING THE DOORS**  
**- PIVOT DOOR**

Handing Bottom Pivot

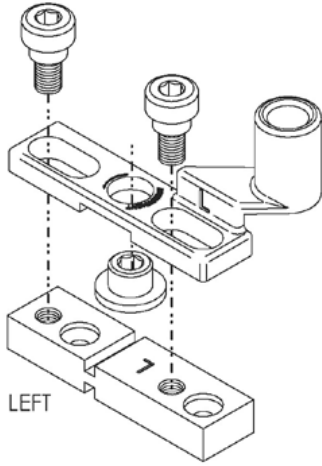

For Right:  
Interchange pivot arm

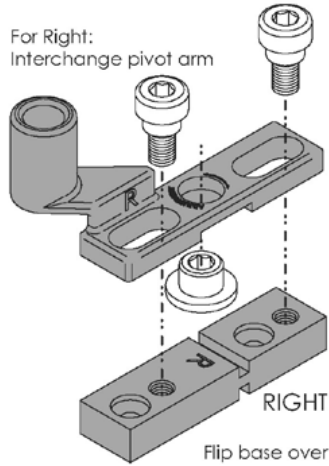

Handing pivot set hinge

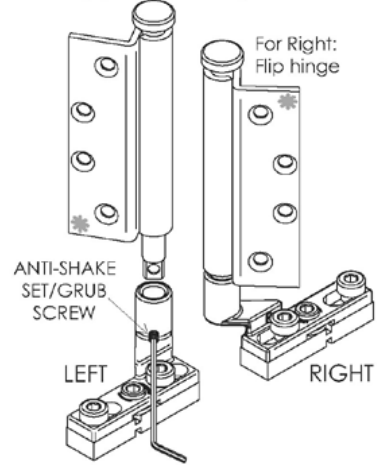

Secure assembly by locking off cap screws

Lock off anti-shake set/grub screw

Insert rollers through access slot, insert pivot and then fix in short track. Lock top pivot into position

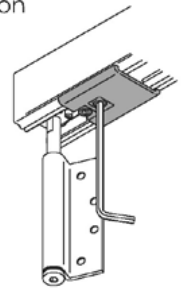
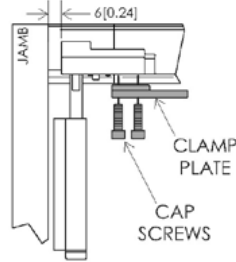
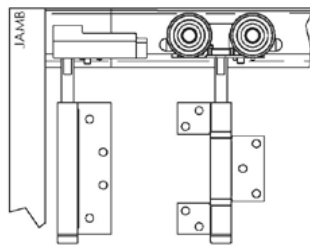
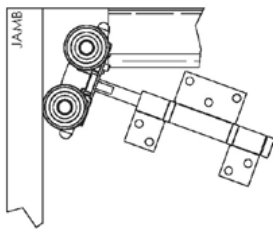

Place bottom pivot in polypropylene channel

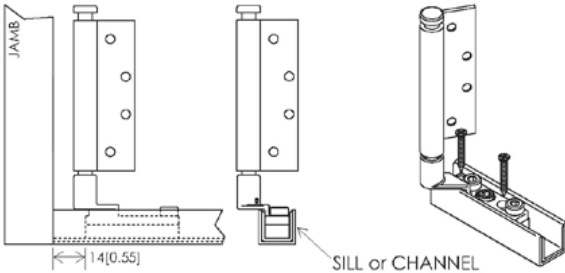

Screw fixings pass through assembly

When cap screws loose, pivot arm can slide freely

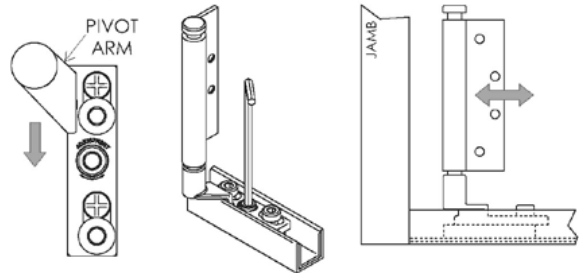

Securely assemble bottom pivot for installation

Fit the keyed flush bolt to the bottom of doors where the pre-machining is done.

Fit the non-keyed flush bolt to the top of doors where the pre-machining is done

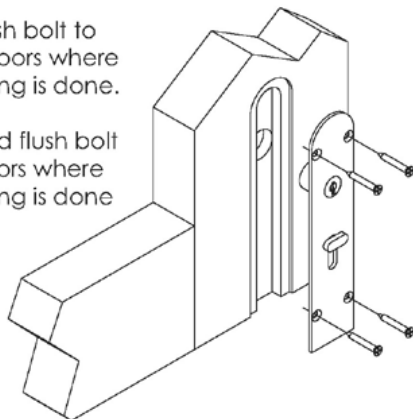

Fit the flush bolt keeper to the frame head in the pre-machined position

Fit the flush bolt dust box and keeper to the sill in the pre-machined position

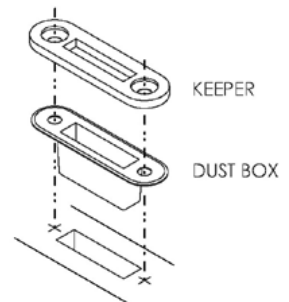

#### 09 FITTING THE MULTIPOINT LOCK

The door leaf that is to receive the multipoint lock is mortised and machined for the face plate of the lock. Once the handing of the door is determined and therefore the top and bottom edges of the doors are established, additional holes need to be prepared through the central mortise as shown on the diagram below.

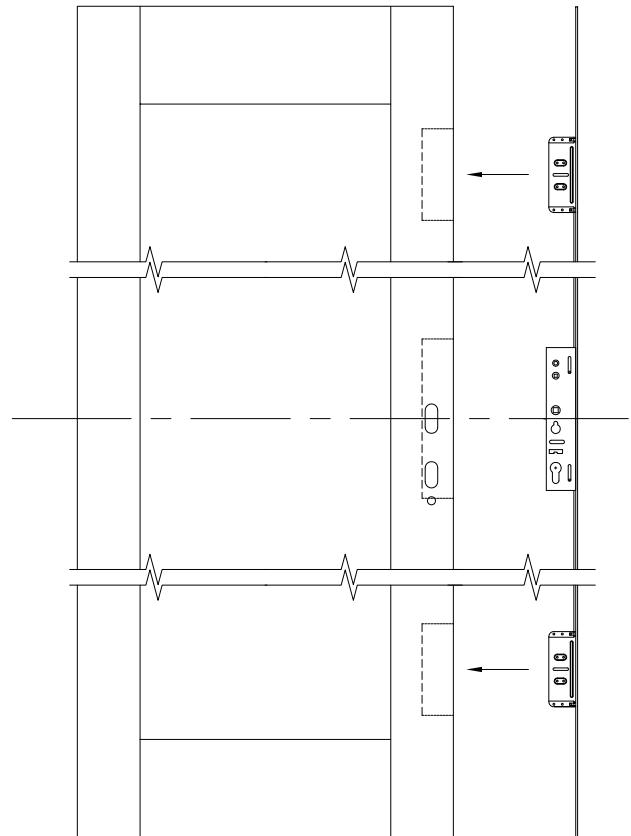
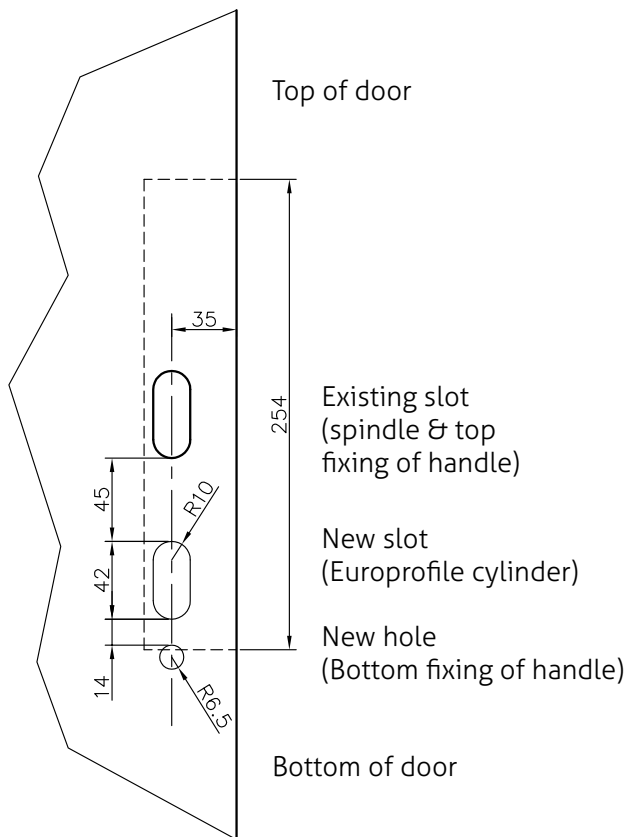

The multipoint lock is loosely fitted into the machined edge of the door, positioned to match the newly prepared holes in the central mortise. It may be useful to loosely fit the handles, spindle and euro-cylinder to locate the lock accurately (see section 12). Pilot drill each fixing position in the face-plate of the lock with holes of 3.0mm diameter and 30mm deep. Secure the lock with the 3.5 x 37mm woodscrews.

## 10 PREPARING FOR MULTIPOINT LOCK KEEPS

For door arrangements other than 3L, 3R, 5L and 5R one door has been machined to receive the keeps for the multipoint lock and will need to be prepared to fit the striker of the central keep as shown in the diagram below.

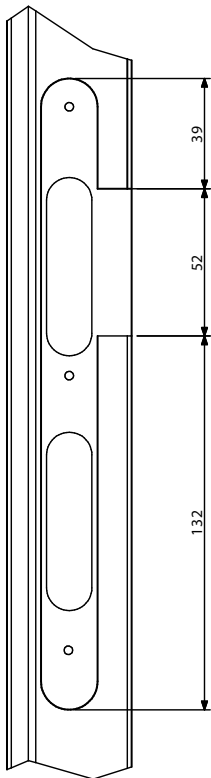

### 11 FITTING KEEPS AND BLANKING PLATES

To complete the frame installation fit the keeps and blanking plates as the positions shown on the arrangement sheet for your doorset

#### FOR 4 DOOR & 6 DOOR SYSTEMS CLOSING TO ANOTHER DOOR.



#### FOR 3 DOOR & 5 DOOR SYSTEMS CLOSING TO THE JAMB



## **12** FITTING THE HANDLES AND LOCK CYLINDER

For the correct operation of the lock, the latch may need to be reversed of the lock.

- Release the screw holding the latch
- Remove the latch, reverse and replace
- Refit the holding screw

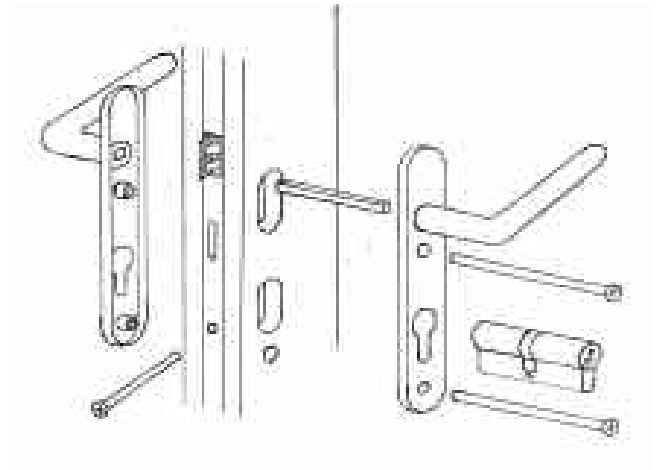

# D Fitting and Fixing Instructions

## Sliding Folding Patio Doorset

### 13 FINAL ADJUSTMENT OF THE DOORS

Adjustments can be made to the top and bottom pivot hinges and to the top intermediate carrier hinge located in the head track.

The top pivot hinge and the top intermediate hinge can be used to raise and lower the doors. Again, these should be adjusted together to ensure an even distribution of load.

The doors should be adjusted so that there is an even gap at the head, sill and jambs.

The target clearance at the head and sill is 5mm and that at the jambs is 6mm but there is both vertical and horizontal adjustment

If movement of the timber has occurred creating clearances greater than the target dimensions the gap at the multipoint lock should be altered by adjusting the pivot hinge(s) so that the latch engages correctly. This may create a clearance at the pivot hinge greater than 8mm but this will be accommodated by the weatherseals on the stile and jambs.

Raise or lower the height of the doors by adjusting the top pivot and intermediate carrier evenly to ensure applied loads are evenly spread to prevent doors bowing.

Push in spring loaded button

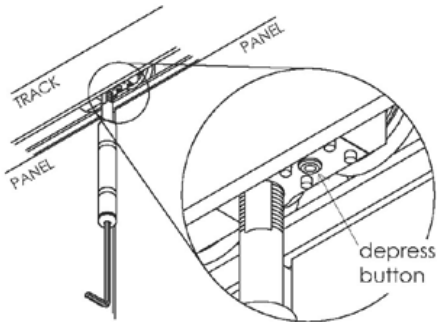

Wind pin into hanger - hanger automatically locks off on bolt flats

Loosen bottom pivot cap screws

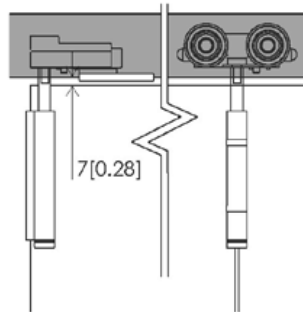

Adjust all hangers and top pivot until panels are level with track

Once panels are level, partially open doors - lock off 1st cap screw

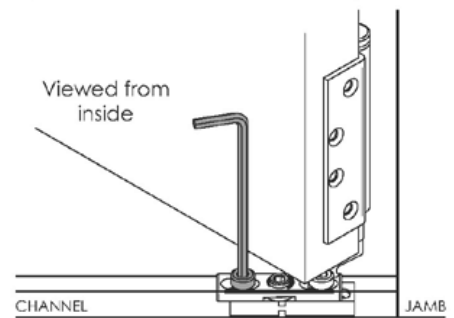

Open fully, lock off 2nd cap screw

Final adjustment, correct spacing.

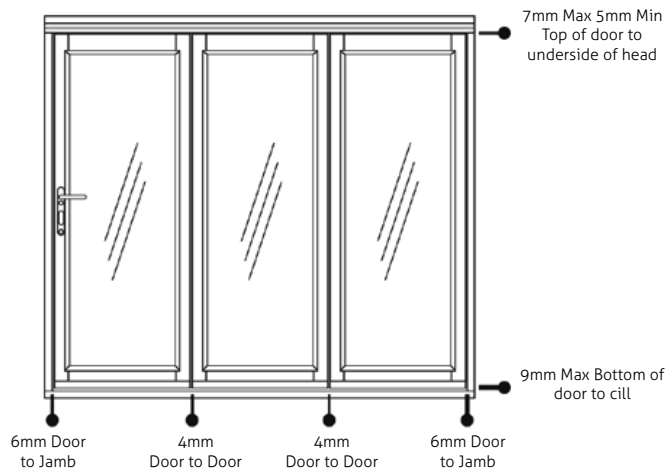

#### **14** FITTING THE VENTILATOR





## **15 FINISHING & MAINTENANCE**

### **FINISHING**

After finishing the installation of your doorset, check that all the fixings are secure and all the specified dimensions are achieved. It is vital for proper operation and long life of your Patio doorset.

The folding sliding doorset is supplied in;

- 1) Unfinished
- 2) Primed
- 3) White or Oak Lacquer

Factory finished requires no further decoration other than touching up damage that may have occurred during installation,

Unfinished doorsets must be primed or sealed immediately after delivery/ collection and prior to installation. This should be carried out in dry weather conditions. All faces, edges and any cutouts should be suitably sealed immediately after unwrapping. Before priming or sealing lightly sand off any handling marks and variations caused by exposure and ensure the surface is dust free.

Unfinished timber can be resinous and will need to be suitably sealed prior to finishing. For paint finishes aluminium primers can provide suitable blocking properties.

Microporous paints and woodstains are recommended for all exterior products.

The manufacturers instructions should be followed. 'Low Build' stains and Danish Oil should not be used.

Pigmented translucent finishes generally perform much better than clear. It is recommended that dark coloured stains or paint should be avoided if the doorset is exposed to the full heat of the sun, particularly on south or south west elevations.

Dark finishes increase surface temperatures and cause excessive drying out, this can lead to surface deterioration requiring more regular maintenance.

### **MAINTENANCE**

These products must be installed in accordance with accepted good trade practice (and in accordance with supplied instructions where applicable), and maintained in accordance with these procedures or else the warranty shall be void.

### **AUTOMATIC CLOSERS AND OPERATORS**

All Door Hardware systems supplied are designed for manual operation only.

### **HARDWARE**

In buildings is subject to deterioration from everyday use, and also from environmental attack due to atmospheric and other conditions. Maintenance of hardware is even more important in severe environments such as coastal marine areas, and some industrial areas. Even stainless steel products require maintenance to prevent deterioration in some environments.

### **TRACK AND BEARINGS**

Using a spatula or similar item (not your finger), apply a small amount (typically a 1/4 teaspoon) of white petroleum jelly (Vaseline) or similar lubricant to the inner lip of each side of the track. Ensure that the wheels pass through the lubricant and it is distributed evenly along the track. Put additional lubricant around bearings. Lubricant reduces wear, improves smoothness and further protects against corrosion of track and bearings. Remove all surface contaminants by wiping all visible track surfaces with a damp soft cloth and a mild detergent, then wipe clean with a clean cloth. In severe environments, apply a thin film of a corrosion preventative by wiping with a soft cloth moistened with one of corrosion preventative products.

Stainless-steel bearings are manufactured from hardening-grade stainless steel and although this material performs considerably better than plated steels, it is still susceptible to corrosion unless maintained as described above.

### **HANGERS, PIVOTS AND BRACKETS**

A light spray application of a corrosion preventative followed by a light wipe with a dry cloth to remove excess is recommended to all hangers, pivots and brackets. Exposed surfaces should first be wiped down with warm soapy water and a soft rag, and then rinsed clean before applying preventative.

### **HINGES**

Wipe down the visible surfaces with warm soapy water on a soft rag and then rinse off by wiping with a clean damp rag. Application of a thin film of a light machine oil or one of the corrosion preventative sprays will help to maintain the original lustre of the metal finish. Be careful not to get these compounds on the timberwork itself as they may cause staining.

### **FLUSH BOLTS**

Spray application of a suitable lubricant to the sliding pin inside the bolt and to the lock cylinder is recommended. A tube attached to the nozzle will help to concentrate the spray where you want it to go.

#### **HANDLES**

Refer to leaflet in box.

#### **FREQUENCY**

The procedures mentioned above need to be carried out as often as is necessary to prevent deterioration in

the installed environment, however we recommend the following minimum frequency of application:

- General environments 6 monthly
- Marine and industrial environments 3 monthly Regular maintenance is required to all hardware, even stainless steel; otherwise the manufacturer's warranty may be voided.

#### **15** **GUARANTEES**

Cimadoor offers the following guarantees on its products & these guarantees are subject to our Terms and Conditions of sale. Defects that are caused in whole or in part by failure to adhere to our recommendations relating to storage, handling, installation, decoration, glazing and maintenance, are not covered by the guarantees:

10 Year Guarantee against manufacturing defects

5 Year Guarantee against glass unit failure

30 Year Guarantee against fungal rot and decay on all external components

5 year guarantee on Hi-build factory painted external joinery in accordance with EN927/1-7

2 year guarantee on Tinted Oak lacquer finish

Exceptional wear and tear of hardware through extreme use is not covered. We will accept no responsibility for products cut down in size after receipt, or when utility or structural strength is impaired in fitting or application of hardware.

Hinges, aluminium rails and other hardware fitted must never be painted, and must be kept clean and lightly lubricated at all times. Use Vaseline or neutral oil. Keep rivets and moving parts lightly lubricated. Lubricate at least once a year, in coastal areas and/or places with high pollution, clean and lubricate more often.

The fitting instructions where supplied must be followed and the assembly, fitting procedures described must be strictly adhered to.

All joinery shall be installed correctly in accordance with normal trade practices and adequately maintained in service.

Any product supplied unfinished should be fully decorated in accordance with the Coating Manufacturers instructions before installation in an external environment. Any areas that have been machined or damaged during installation should be touched up to prevent coating breakdown.

We accept no responsibility for failure of product caused by inadequate or unsuitable decoration. All edges, corners, tops & bottoms of doors must be adequately decorated.

These are the minimum requirements and further finishing coats must be applied to the manufacturers' recommendations to afford full protection.

Take care not to paint over any form of weather stripping, as this will adversely affect their performance.

Any surfaces subsequently cut, particularly those exposing end grains, must be brush coated with preservative and if required for paint finish must also be primed before the joinery is fixed in position in accordance with British Standards or Euro codes.

The decorative finish applied to external joinery must be maintained in service and moisture must not be allowed to penetrate into the timber throughout its life.

Regular maintenance of the paint or stain finish of the frame is essential for the long-term performance of all the components of your patio doorset. The period between maintenance checks will vary depending on the type of paint or stain finish and also the local conditions for the site. External joinery products must be cleaned at a maximum of six monthly intervals using a mild non-abrasive cleaner and soft cloth.

Both internal and exterior faces should be cleaned.

Make regular checks to ensure that any drainage holes, channels and spaces are kept clear. Use a soft flexible brush or pipe cleaner with care to remove obstructions.

Finished joinery is guaranteed against blistering, cracking, flaking or erosion excluding natural resin exudation and movement around knots.

Annual inspection should be made and touching up carried out as necessary in areas of wear and tear (for example, exposed areas of sills or where the paint film has been breached).

Guarantees to the finished product are also on condition that:

- No physical or chemical damage to the doorset or coating has occurred
- No repairs or alterations to the surrounding buildings have occurred which are detrimental to the joinery performance.
- No failure of the coating has occurred caused by failure of ancillary products, or glazing.
- No damage to the coatings has occurred prior to, or during, installation.
- No damage to the coating has occurred, caused by bad maintenance of the building or poor design of the building.



CLIMA DOOR